

True Ice Series

Modular Commercial Cube Ice Machine

Model: **TCIM-422**



TrueTouch®



AIR-COOLED • TCIM-422-HA1-A

(Shown on a TIB-422 ice bin. Sold separately.)

22" W x 24" D x 22" H
(56 x 61 x 56 cm)



CUBE SIZES

HALF

7/16" x 1-1/8" x 7/8"
(11.1 x 28.6 x 22.2 mm)

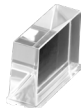

FULL

7/8" x 7/8" x 7/8"
(22.2 x 22.2 x 22.2 mm)



LARGE

1-1/8" x 1-1/8" x 7/8"
(28.6 x 28.6 x 22.2 mm)



- Produces up to **450 lbs (204 kg)** of ice per 24 hours
- Exceeds ENERGY STAR® standards by **up to 37%**
- Eco-friendly **R290** refrigerant: **4.3 oz (122 g)**
- **One-touch** cleaning

FEATURES & BENEFITS

▶ Superior Sanitation & Maximum Efficiency

- **TrueNcapsuL8®** patented, fully insulated, sealed evaporator inhibits mold and bacteria growth
- **TrueZone®** air purification cleans air in food zone and bin with advanced growth-inhibitor technology*
- **TrueGuard™** antimicrobial protection built into molded components and bin liner
- **Shortest cycle times in the industry** — fast ice production with no harvest assist required
- **Wide operating range: 35 °F to 110 °F (1.6 °C to 43.3 °C)**
- **One-touch cleaning** with tool-free, removable food zone parts

▶ Advanced Diagnostics & Ice Level Monitoring

- **TrueTouch® 4.3" smart touchscreen** with predictive diagnostics and clear system status — no cryptic codes
- **High/low-pressure transducers** for gauge-free servicing
- **Visual and audible alarms** with push notifications
- **Programmable ice production scheduling**
- **Time-of-Flight™** real-time ice level monitoring — no thermostats required

▶ Remote Monitoring

- **Remote monitoring** with easy back-end data access
- **Location-based performance optimization**
- **Remote shut-off** capability

*TrueZone® is an optional accessory, sold separately.

True Ice Series

Modular Commercial Cube Ice Machine

Model: **TCIM-422**



PLAN VIEW

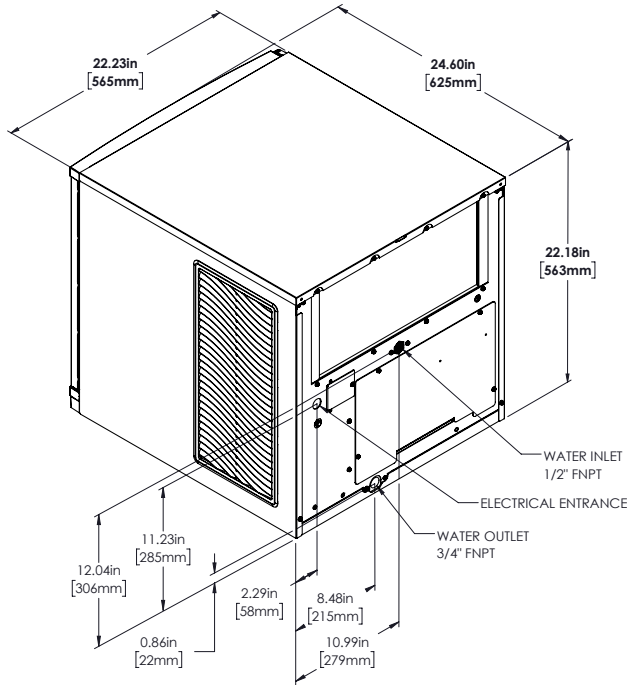

CLEARANCE

PLEASE NOTE: air-cooled units require **6" (152.4mm)** clearance for air intake and exhaust on the left, right, and back sides.

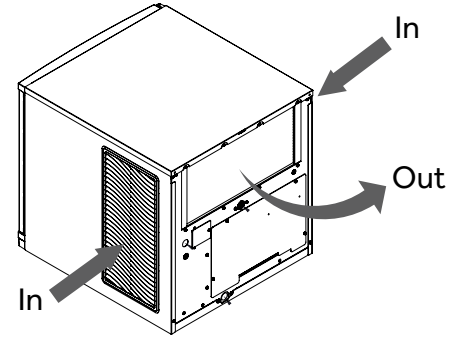

ADDITIONAL FEATURES

- TrueTech® clear-coated exterior with superior corrosion and fingerprint resistance
- Removable air filter and RCU technology
- Micro-channel condenser for superior efficiency
- Ultra-quiet fan operation

SPECIFICATIONS

AIR COOLED			ICE PRODUCTION / 24 HOURS				Peak Heat of Rejection BTU/hr
True Ice Series Model	Cube Size	Crated Weight (lbs)	70°F Air / 50°F Water (21° Air / 10°C Water)	90°F Air / 70°F Water** (32° Air / 21°C Water)			
			Ice Production (lbs)	Ice Production (lbs)	Potable Water Consumption/100lb	Electrical Consumption/100lb	
TCIM-422-HA1-A •	Half	164 (74 kg)	450 (204 kg)	348 (158 kg)	15.2 gal	4.47 kWh	5,700
TCIM-422-FA1-A	Full		440 (200 kg)	330 (150 kg)		4.65 kWh	
TCIM-422-LA1-A	Large		430 (195 kg)	310 (141 kg)		4.80 kWh	

• Energy Star Model

ELECTRICAL		CONNECTIONS	
Voltage	Min Circuit Ampacity	Potable Water In	1/2" Female NPT
115/60/1	15	Water Out	3/4" Female NPT
		Electrical Connection Junction Box	104-127 VAC/60Hz/1

OPERATING REQUIREMENTS		
	Minimum	Maximum
Ambient Air Temp	35°F (1.7°C)	110°F (43.3°C)
Water Temp	35°F (1.7°C)	100°F (37.7°C)
Water Pressure	20 psi (138 kPa)	100 psi (689 kPa)



ACCESSORIES

- TrueZone® Ozone Growth Inhibitor Device
- True Platinum and Standard Water Filters & Filter Kits



**Performance specifications are subject to change. For the most up-to-date information, please visit [Energy Star's website](https://www.energystar.gov).